



SUZUKI GSX-R 750

(2008)

STREET LEGAL EXHAUST SYSTEM

www.akrapovic.com

The Akrapovic SLIP-ON is a partial system and is a base-level exhaust system tuning component. It provides a major performance improvement for the Suzuki. The system is designed for riders who are looking for a combination of performance, quality, simple installation and affordability. With the Akrapovic SLIP-ON single muffler system you will also benefit from a major weight saving. Racing-oriented riders should check out our Racing and Evolution complete systems. Please note that the single muffler SLIP-ON is available in the open and street legal version.

PERFORMANCE

Measurements of the Akrapovic SLIP-ON system on the SUZUKI GSX-R 750 (without noise damper):

Power & Torque: The power curve with the Akrapovic exhaust system is much more linear, from the bottom to the top of the power curve. Max. power of 135.4 HP is reached at 13200 rpm. The torque curve reflects the same compatibility with the operation of the engine. The increase can be seen throughout the entire rpm range, so you get bags of torque to go along with the loads of power. The largest power gain of 4.6 HP is at 13200 rpm. All our measurements are with standard Suzuki mapping.

CONFIGURATION

The Akrapovic SLIP-ON system is composed of a conical titanium link pipe and muffler. The link pipe is attached to the stock header assembly with sleeve joint and metal clamp. The sleeve joint between the link pipe and muffler is secured with silicon shielded springs. The muffler is attached to the frame with an Akrapovic carbon-fiber clamp. The inlet cap and inner perforation of the muffler are made entirely of titanium, and the outer sleeve is available in either titanium or carbon-fiber. The outlet cap is available only in carbon fiber.

	PERFORMANCE		
	stock	AKRAPOVIC	max. increased power
max. rear wheel power HP / rpm <small>(measured on Dynojet ATV)</small>	130.8 / 13150	135.4 / 13200	4.6 / 13200

	CONFIGURATION		
	header tubes	collector	link pipe
material	-	-	TITANIUM
tube shape	-	-	CYLINDRICAL

interference crossover tubes	-	lambda sensor	YES	
header tube inner sleeves	-	header tube flanges	-	
header tubes - collector connection	-	collector / header tube - link pipe connection	SLEEVE JOINT + METAL CLAMP	
link pipe - muffler connection	SLEEVE JOINT + SILICON SHIELDED SPRINGS	muffler inlet cap /outlet cap	Ti / Carbon-fiber	
muffler metal interior	TITANIUM	muffler outer sleeve	Ti / Carbon-fiber	
muffler clamp	CARBON-FIBER	muffler bracket	-	
muffler insert	EU	YES	heat shield	-
	US	-	catalytic converter	-

	ADDITIONAL DATA				
	stock	AKRAPOVIC		difference	
		S.S. link pipe	TITANIUM link pipe	stock - S.S.	stock - titanium
weight comparison (kg)	2.86	-	1.69	-	1.17

noise measurements (dB / rpm)	stock	AKRAPOVIC
	94 / 6750	97dB / 6750(open) ; 94dB / 6750(homol.)
possibility of periodic service without removing A.E.S.	oil	oil filter
	YES	YES
legal for street use	NO / YES	

Technical specifications of Akrapovic exhaust systems and related products subject to change without notice.



Product code: S-S6SO6-HZC
S-S6SO6-HZT



Product code: S-S6SO6-HZC
S-S6SO6-HZT



Product code: S-S6SO6-HZC
S-S6SO6-HZT



www.akrapovic.com
Akrapović d.d. 2008 all rights reserved

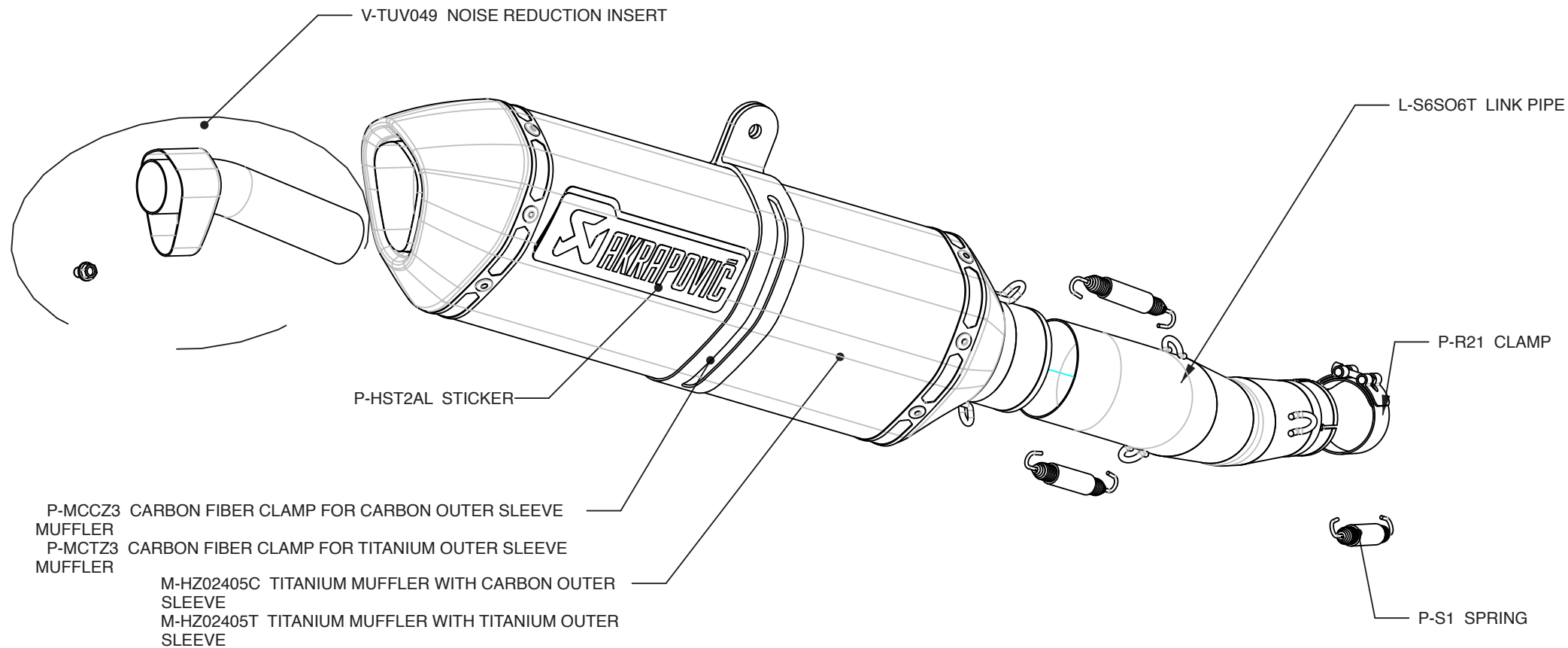

Product code: S-S6SO6-HZC
S-S6SO6-HZT

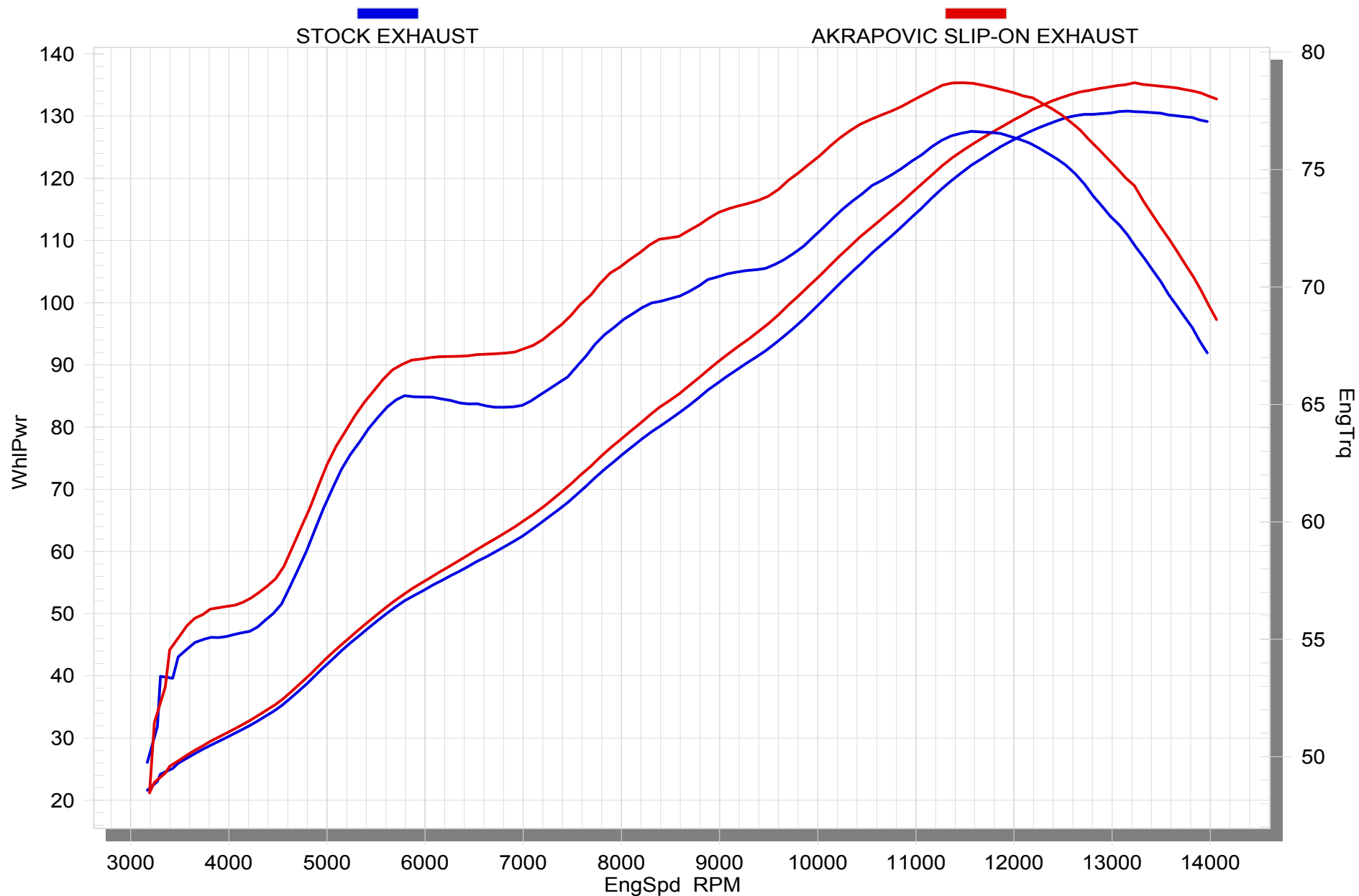

Product code: S-S6SO6-HZC
S-S6SO6-HZT

